

CNC PRODUCTION

Routing Tools

MULTICAM

CNC ROUTING MACHINERY



edition 21

We Point You In The Right Direction

60-000

60-100

60-200

60-300

56-000



Download
your copy.

TABLE OF CONTENTS

SOLID CARBIDE
SPIRAL

SOLID CARBIDE
STRAIGHT

SOLID CARBIDE
COMPRESSION
SPIRAL

SOLID CARBIDE
FINISHER

SOLID CARBIDE
SPIRAL

SOLID CARBIDE
STRAIGHT

STRAIGHT



Tool Material and Geometry 3-8

TOOLS FOR ROUTING TIMBER

Solid Carbide Three Edge Rougher	9
Solid Carbide Three Edge High Helix Rougher	9
Solid Carbide Two Edge Chipbreaker/Finisher	9
Solid Carbide Three Edge Chipbreaker/Finisher	9
Solid Carbide Two Edge Compression Spiral	9
Solid Carbide 4E HV Spiral Upcut	10
Solid Carbide Three Edge Finisher	10
Solid Carbide Marathon Compression Spiral	10
Solid Carbide MAXLife Compression Spiral	10
Single Flute Upcut Spiral Cutters with "O" Flute Geometry	11
Single Flute Downcut Spiral Cutters with "O" Flute Geometry	11
Solid Carbide Double Edge Straight Cutters	12
Solid Carbide Single Edge Straight Cutters	12
60, 90 & 120 degree "V" Groove Cutters	15
Surface Planning Tools	12
Plunge Routing Tools	12

TOOLS FOR SPECIAL APPLICATIONS

Solid Carbide Traditional Classic & Core Box Cutters	13
Ball Nose Cutters	15
Specially Designed Engraving Tools	13
Dowell Drill Bit for Melamine board	13
Shelf Hole Drills	13
High Performance Composite Router	19
Tools for Grooving ACM	19

TOOLS FOR ROUTING PLASTICS

Single Flute Straight Cutters with Special "O" Flute Geometry ...	16
Single Flute Upcut Spiral Cutters with "O" Flute Geometry	16
60, 90 & 120 degree "V" Groove Cutters	15
D Cutter	16
Single Flute Downcut Spiral Cutters with "O" Flute Geometry ...	17
Solid Carbide Single Straight Cutters	17
Ball Nose Cutters	15
Solid Carbide Saw Flush Mount	17
Solid Carbide Foam Cutters	17

KNIFE BLADES & TOOLS FOR ROUTING COMPOSITES

High Performance Composite Router	19
Blades for Multicam Tangential Oscillating Knife	19
Specially Designed ACM V Grooving Cutters	19
Diamond Tipped One Flute Mortise Cutter	19

TOOLS FOR ROUTING NON-FERROUS METALS

Solid Carbide Up Spiral Cutters with Small Cut Diameters	18
Solid Carbide Up Spiral Cutters	18
D Cutter	18

ACCESSORIES

HSD Spindles & Aggregates	11
Tangential Knife Head Attachments	21
ISO30 Tool Holders & Collets	8

A. Routing

Routing is an effective method of machining materials such as wood and wood by-products, plastics, composites and non-ferrous metals. The high frequency spindle that we offer operates at extremely high speeds with the ability to vary RPM and feedrate, you can now see a change in your production time without sacrificing edge quality. With the increasing changes in the geometry of router bits and sometimes the pure imagination of the operator, the router becomes one of the most versatile machines in the industrial marketplace.

B. Tool Selection

We carry a selection of solid carbide tools for woods, plastics, composites and non-ferrous metals. Solid carbide tools allow for longer tool life and faster feed rates. Tool materials are not equal in quality. High speed and carbide grades vary along with heat treatment and the sintering processes. The tools we supply are manufactured with quality materials, which meet inspected raw material standards consistent with production routing requirements. Most carbide tools are C-2 or similar carbide grade. We carry only tools manufactured with production proven microgram carbides. Diamond tipped router bits should only be considered when the environment, the material being cut and the economics of production point to it's usage.

C. Tool Geometry

Use double edge router bits when finish is the primary consideration.

Use single edge router bits when speed is the primary consideration and finish is less important.

Use upcut spiral router bits for grooving, slotting or when fast chip removal is required.

Use spiral, straight or shear tools for natural woods depending on type of cut required.

Use spiral, straight or shear carbide tools for composites, particleboard, plywood or MDF.

Use spiral tools when finish and/or available horsepower are problems.

The cutting length of the tool is very important to the finish. Use the shortest cutting length allowable, based on the material thickness. Using a tool with a cutting length that is longer than required can cause vibration, deflection and an inferior finish.

In general, the cutting length should not be more than four times the cutting diameter. Bits with a cutting length over four times their diameter will be subject to increased breakage.

Use the largest tool diameter allowable for increased rigidity, finish and tool life.

TOOLING MATERIALS

Solid Tungsten Carbide

Tungsten carbide is a cement mixture and like concrete, is composed of very hard particles. Solid carbide is generally the toughest material available. Bits produced with this material stay sharper longer.

Carbide-Tipped

Carbide-tipped tooling provides some of the edge longevity of carbide with the lower cost of a steel base. Carbide tipped bits are only available with straight flutes.

High-Speed Steel

HSS is a poured material, chemically and metallurgically bonded together. The steel is processed from raw ore and heated to a liquid stage where several minerals and elements are added to improve the internal structure. Typically, HSS's tool life is not as long as carbide. HSS is seldom used in wood applications because carbide tooling stays sharper longer. HSS is generally preferred for metal cutting and some plastic cutting operations.

Ceramic and Diamond

This tooling is worth considering when carbide's life is not acceptable. The major consideration here is the cost.

TOOL GEOMETRY RELATIVE TO SPECIFIC MATERIALS

Straight Flute

Use for wood and plastic operations. The straight flute design, in single or multiple cutting edges, produces a clean finish. The harder the material, the more cutting edges are recommended. The straight flute does not allow for the lifting of material out of the cut.

Spiral Flute

Use for aluminum, wood and plastic operations. The up-spiral flute is especially good for chip removal. When cutting aluminum and plastic, remelting of the chips is primarily the source of poor cut quality.

Chipbreaker

Use for wood roughing or hogging operations. The chipbreaker is designed to break up chips for fast, clean, and efficient removal while reducing overall chip load.

TROUBLE SHOOTING

For every problem there is a possible cause and a solution. Here are some typical problems that you may encounter and possible solution for each problem.

Problem	Cause	Remedy
Tool Breakage	Heat due to poor tool selection	Use correct tool for material being cut.
	Heat due to inadequate chip removal.	Use upspiral tool to help in chip removal.
	Too high a plunge rate.	Reduce plunge rate.
	Dull tool.	Replace tool.
	Tool runout.	Tighten tool in collet or if necessary change collet.
	Worn collet.	Replace Collet.
	Too high a feedrate.	Reduce feedrate.
	Too high a Chipload.	1. Reduce feedrate. 2. Increase RPM. 3. Increase number of flutes.
	Vibration.	Secure material correctly to bed.
	Tool not properly colleted.	1. Insert more of shank in to collet. 2. Use collet plug.
Tool deflection.	Reduced feedrate but if possible use larger diameter tool.	
Chip rewedding to cut edge	No Coolant	Use mist coolant or cold air gun
	Dull tool	Replace tool
	Too slow a feedrate	Increase feedrate
	Incorrect tool selection	Choose correct tool for material being machined
	Head due to inadequate chip	Use up spiral tools.

ROUTER BIT GEOMETRY

Basic Terms

Helix Angle. Angle of the cutting flute. It is measured relative to the axis of the cutting tool.

Flute Fadeout. The length between the end of the cutting length and the begin of the shank length

CEL. Cutting edge length.

Shank Length. The length of the cutter shank that can be inserted into the collet.

OAL Overall cutter length.

CED Cutting edge diameter.

Shank Diameter. The diameter of the shank to be inserted into the collet.

Single Flute

Use for faster feed rates in softer materials. The single-flute cutter typically has lots of room for chips, but the single cutting edge limits either the feed rate or the hardness of the material to be cut. These types of cutters are especially recommended for plastics.

Double & Triple Flute

Use for better finish in harder materials. Double-flute bits provide a smoother cutting action because the chip load is smaller than a single-flute cutter for a given feed. This allows harder materials to be handled.



Upcut Spiral

Use for grooving or slotting, for upward chip evacuation and best finish on bottom side of piece part. These bits allow for rapid cuts since the tool clears the chips away from the material. This type of tool is not recommended for softer materials such as MDF because of the ragged finish that can result on the top surface. This type of geometry is used whenever the best finish is needed on the bottom side of a part.



Downcut Spiral

Use for downward chip flow, better hold-down in fixture and best finish on the topside of the cut part. Note: that the cutting speeds usually have to be reduced because the chips are pushed back into the material.

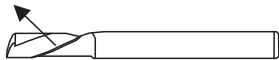

Up/Down Spiral (Compression Spiral)

Use for double-laminated material and best finish on top and bottom side of piece part. Because of the spirals all the chips are forced back into the material. This results in a very clean cut on the top and bottom edges, but the cutting speeds have to be reduced. Note that the center of the spirals should be approximately in the center of the material for best results. This usually means that a substantial waste board would have to be used.



TOOLING MAINTENANCE

Tool Life

Tools should be changed at the first sign of edge deterioration causing finish degradation or increase in operator effort to maintain feed rates. Never allow the tools to dwell in a cut. The router bit should be fed in such a manner so that in moving through the work it has a chance to bite or cut its way freely. If the feedrate is too fast, strain and deflection will occur. If fed too slowly, friction and burning will occur. Both decrease the life of the router bit and are common causes of breakage.

The router mechanism must be well maintained for any cutting tool to perform properly. Routinely check the collet for wear. Inspect tools for collet marks indicating slipping due to wear or dust build up. Check spindle on a dial indicator for run-out. Collet and run-out problems cause premature tool failure and associated production difficulties.

Do not use adaptor bushings to reduce size of the collet on a routing or production basis. Tools will not perform properly in bushings over an extended period of time. Bushings are for prototype, experimentation, test and evaluation and not for production.

Wherever possible, use a coolant when routing. Heat caused by action between the tool and piece part is enemy #1 to tool life, Heat is a function of surface footage per unit of time, thus, the more dense the material, the faster the feed rate to minimize heat. However a compromise must be reached between finish and heat.

Tool life is affected dramatically by tool geometry. Rake and clearance angles, as well as cutting edge length should be examined. Router bit breakage is most often caused by a misapplication of the router bit. Do not assume the proper router bit is being used.

Tool Breakage

In spite of the structural and metallurgical attributes, which are designed into industrial and professional router bits, breakage occurs. A detailed examination yields the following:

Application related breakage:

Cutting edge lengths should be as short as possible to accommodate length of cut required. Larger cutting edge diameters require larger shank diameters. Spiral geometry can direct chip flow and expel chips to reduce heat. When tool application is a problem, changing the type of tool is the only solution.

Tool quality shortcomings:

Upon investigation an internal flaw in the steel or carbide can cause failures. These failures are normally random, however, if the flaw was raw material batch based, an entire batch may be a problem. The same is true for heat-treating. Too high a hardness can lead to premature edge failure. This is generally confined to one batch of tools. Geometry induced fractures usually are related to improper rake and clearance angles as manifested in the bit riding the cut. The resulting heat generated by friction shortens edge life, tends to create burn marks and may cause the chips to accumulate behind each cutting edge and culminates in fracture. A shank out of round prohibits effective colleting and does not permit the tool to turn in a concentric manner. The whipping action generated is catastrophic to bit life and failure by fracture is imminent.

Router Collet Integrity

A router bit is rendered nearly useless if the mechanics of gripping and rotating the tool are not made to the same of accuracy as the tool. Overt signals such as breakage and dark markings on the shank of the bit warrant immediate investigation, Inspect the collet for out of round or bell mouthed conditions. Operators often overlook inspecting new collets based on the assumption that a new collet is geometrically correct. Tool manufacturers are aware and openly share the subtle nature of this problem. Dirt, dust, bonding agents and sap can also affect collet performance, which occupy space and accelerate wear.

INSTRUCTIONS FOR INSERTING TOOL BITS

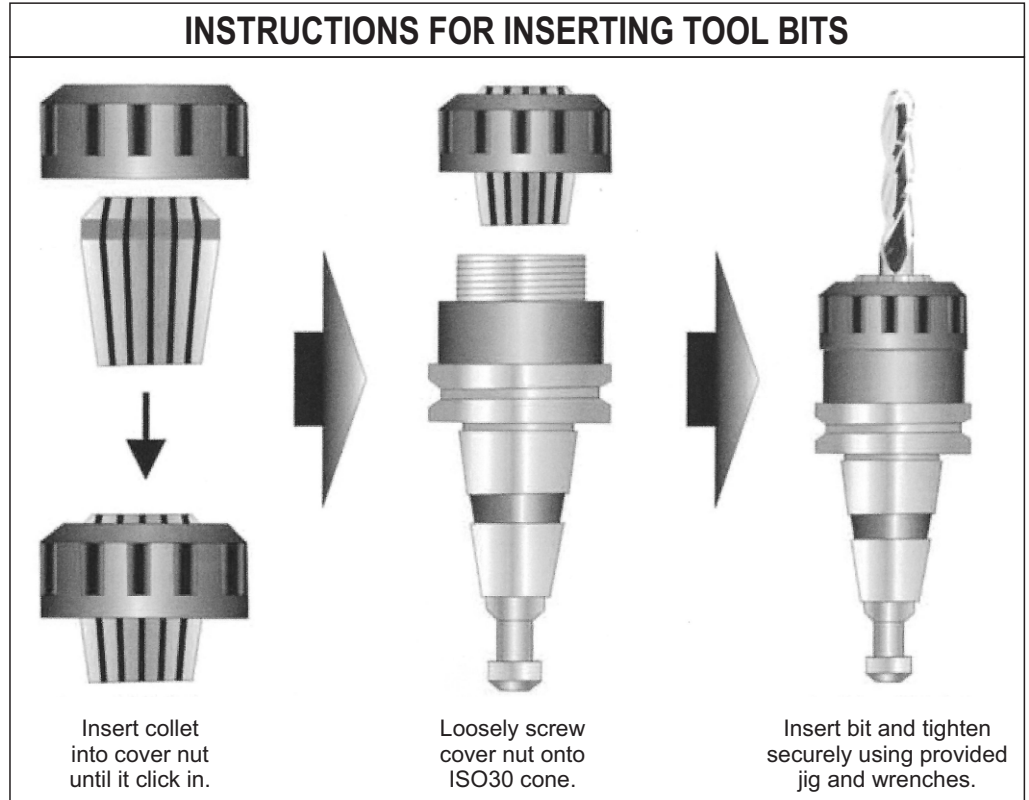
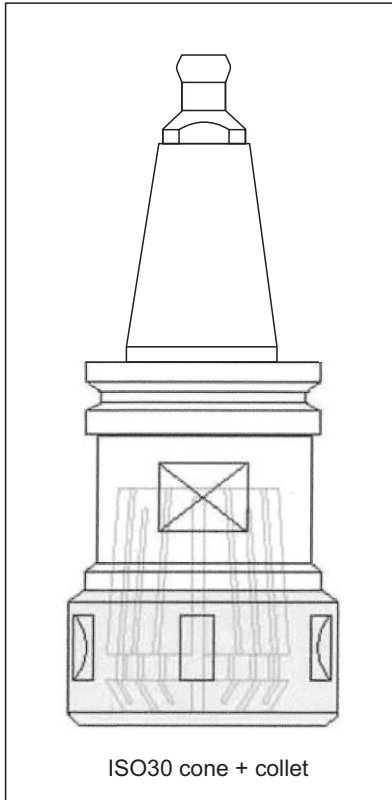

Operator Breakage

If the router bit is within specification, tool breakage can still occur through incorrect routing techniques. Specifically feeding the router bit into the material must be accomplished in such a manner, that the router bit is permitted to “bite” or “cut” its way freely. If the router bit is fed too fast, excessive strain is imposed on the tool, conversely if the router bit is fed too slow, excessive friction will be generated, causing destructive heat buildup. In both situations, tool life is significantly shortened or in sustained conditions, tool fracture is imminent. Any router bit can be broken should that choice be made in the operating of the router.

Suggested Procedure

Should all of the above examinations be inconclusive, it is important to retain both new and used sample tools (all pieces if broken). Please contact Multicam Systems and inform them of your issue. The following information should also be provided: router type, material being cut, spindle speed, feed rate and cutting conditions (mist oil) when breakage occurred. This data should provide enough clues for a solution to the tool breakage issue.

Collet Maintenance

Collet maintenance is one of the most common causes of inadequate tool life or breakage. There are a number of links in the chain that make up this critical tool holding system called a collet.

As a chain is only as strong as the weakest link, a router bit can only be as good as the system that holds it properly. The small amount of time spent to regularly inspect and clean the collet system, will be more than offset by increased productivity and a reduction in overall costs.

The five critical components are as follows;

1. Internal Collet Clamping Surfaces

The most important link in the tool holder chain is the inside of the

deposits itself on the inside of the collet, This resin build up, if not removed, causes the collet to grip inconsistently on the tool shank. By not applying equal pressure throughout the entire gripping range of the collet, the tool holder allows the tool to resonate inside, causing slippage inside the collet. Slippage can cause “fretting”; a condition in which resins are deposited on the shank of the tool. This resin buildup can be easily removed from the inside of the collet with Rust Free and brass tube-type brushes. These brass brushes are non-destructive and in conjunction with Rust Free can adequately remove the deposits. Rust Free should be sprayed on and quickly brushed and wiped completely dry. Do not let the liquid sit and air dry.

2. Internal Spindle & Collet Taper

The inside taper of the spindle and tool holder is a critical surface which accumulates resin build up and should be cleaned at each tool change to maintain best concentricity. Felt brushes are available to fit most taper sizes and provide a quick means of removing short-term buildup.

3. External Collet & Tool Holder Taper

The outside taper of the spindle and tool holder require regular inspection and should be cleaned of all deposits each time the tool is changed, Brass brushes work well for this application, but felt cloths can also be used if the tapers, are regularly maintained and the buildup is minor.

4. Clamping Nut Surfaces

The inside taper of the nut should be clean and free of burrs on the surface. Any surface burrs or contamination will not only skew a collet but can also permanently ruin a new collet. The clamping nut should be cleaned with a brass brush during every tool change. Special care should be taken to examine the clamping nut threads on a regular basis.

5. Tool Holders

Tool holders such as the ISO 30 have additional matching and mating tolerances beyond those of the older tapers. Because of their unique design, these tool-holding systems can be more prone to runout caused by resin buildup. "Fretting" or "Bronzing" will cause inconsistent gripping in the taper and/or the flat mating surface and reduce consistency of tool life. If ignored, these conditions can eventually produce premature spindle failure. The mating surfaces should be cleaned with Rust Free and hand dried immediately.

Note: To ensure trouble free operation, always insert the collet into the collet nut until it clicks in and thread it loosely onto the spindle prior to inserting router bit. All five of these components are critical and should be regularly maintained. One more item not to be overlooked is that collets should be replaced on a regular basis, approximately every 400 to 600 run time hours. This means inspection for metallic damage such as bell mouthing with every tool change. If metallic damage is visible, the collet should be discarded and replaced. Also consider that even if there is no damage present the collet can be worn out through metal fatigue. Heat is directly transferred from the tool to the collet. These heating/cooling cycles remove the original tempering of the steel. Collets are made from spring steel allowing them to have a certain amount of elasticity to grip the tool. As the heat cycle is repeated this elasticity diminishes. Over time, a collet requires increased tightening to maintain the tool in proper position. As over tightening increases, the collet is distorted, creating eccentricities in the tool holder. Therefore, instead of over tightening older collets and creating a number of other problems, the collet should be replaced. Often the cost of a new collet can be offset by the cost of needlessly broken tools. Proper positioning of the tool in the collet is critical. The tool should only be gripped on the shank portion of the tool. At no time should any portion of the flute fadeout be inside the collet.

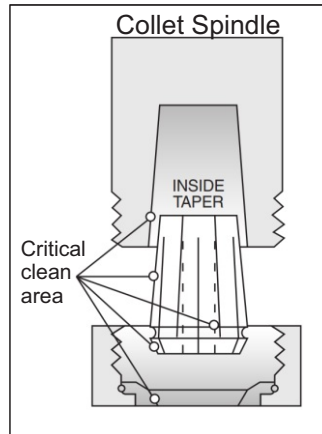

Proper Collet Use & Maintenance

Many users select tools without regard to the importance of adequately holding them in the collet. We like to think of the spindle-collet system as a chain and just like a chain is only as strong as its weakest link, so too is the collet's relation to the tool. A high performance tool can only perform if the collet is properly maintained each and every time the tool is changed.

FULL GRIP COLLETS

Full Grip Collets are identified by their slits that run from both ends, almost cutting the collet in pieces. This type of collet tends to have more flexibility and often comes in what is termed as "Range Collets", which allow gripping in a range of shank sizes. This full grip type allows gripping over the entire length of the collet and to be properly used, the collet should be 75-80% full. The most important portion of the collet is the mouth, which is at the bottom. This area is important because all the lateral pressure taken by the tool must be evenly distributed on all ears of the collet for it to cut true or concentric. It is very critical that the 80% rule be followed when using a full grip collet due to the ability of the collet to flare at the back if not full. The collet can

actually allow tool movement in very minute amounts often times resulting in tool breakage. There are times that the 80% is not possible due to shank length available, so it is necessary to fill this void in the back of the collet with a life plug that is of the same size as the shank, thus to avoid the collapsing problem. Equally as important as filling the collet properly, it should also be understood that it is possible to over-collet as well. This is when the "Flute fadeout" portion of the tool is allowed to extend up inside the collet. This does not allow a firm equal grip by all ears of the collet at the mouth. This allows the tool to have uneven support at the most critical area. Often times with solid carbide, or high speed steel tools, the tool material is hard enough to actually scar the inside of the collet, causing permanent damage to the collet.

This can also be common cause for tool breakage when it occurs. Breakage often results in permanent damage to the collet due to intense pressure exerted often either "Burring" or "mushrooming" the mouth of the collet.

Heat is the biggest enemy of the tool, and the first place the heat goes from the tool is into the collet. It is also important to note that collets are made of spring steel that can, and will over a period of time lose its elasticity and harden, making it increasingly tougher to tighten adequately. As this hardening takes place, the steel does not fatigue evenly and often causes the collet to grip tighter on one side than the other, creating runout in the tool. It is important to understand that if they are overrun enough, this over tightening will eventually damage the internal spindle taper resulting in costly repairs. Because it takes place over a period of time, it is very hard to notice but, a safe recommendation for collet life is in the 400 -600 run time hours. This is about 3 months in a two-shift operation of normal run times. If collets are not changed, they will eventually become brittle enough to crack or break in half potentially permanent spindle damage that could have been avoided. Just like changing the oil in your car, it is good preventative maintenance that should be done regularly. Just as replacement is important, equally as important is cleaning the collets each and every time the tools are changed. Collets are in a brutally dirty environment and are expected to perform a very accurate task while undergoing some real extremes of heat and dirt. As material is routed, whether it be wood, plastic, aluminum or man-made board, the chips carry with them many resins that migrate up the slits in the collet and deposit themselves onto the inside of the collet ears, usually nearest the mouth of the collet. This minuscule vibration is often the cause for tool breakage when seen in the actual shank area of the tool instead of down by the cutting edge. The resin acts like pressure points gripping the tool tighter at the mouth of the collet. These pressure points often distort the grip on the tool creating runout. This resin heats up as the tool does and actually ends up depositing itself onto the shank of the tool almost gluing the tool into the collet leaving brown marks at the mouth of the collet contact on the shank. These brown marks are sure sign of collet neglect. To prevent this problem the resin must be removed from all surfaces that it is prone to buildup. Using a non-abrasive brass lube brush for the inside of the collet, and a mild solvent and rag for the external surfaces of the collet and inside spindle taper. It is important to point out that blowing out the collets does not get rid of the resin, nor does soaking them overnight in thinner. A brass brush is the best thing, along with some of the citrus-based cleaners available, allowing them to be safely used on the shop floor. Do Not Use a petroleum based lubricant for cleaning, as it will only act as a magnet for all the dirt and dust by the residue it leaves behind.

Calculating Feeds and Speeds

There are certain parameters that must be considered, before setting up any file for cutting if you are to accomplish the finish and accuracy required. One of the most important of these factors is the chipload per Tooth (Cpt). chipload can be defined as the size or thickness of the chip that is removed with each flute per revolution.

When material is machined the cutter must revolve at a specific RPM and feed at a specific feedrate to achieve the proper chipload. There are also several factors to be considered when choosing the proper RPM and feedrate.

The feed rate used depends upon a variety of factors, including power and rigidity of the machine, rigidity of part hold-down, spindle horsepower, depth and width of cut, sharpness of cutting tool, design and type of cutter, and the material being cut.

To obtain the optimum chipload, we must consider the variables listed above, along with the machine and materials we intend to cut. This will help us find the best feed rate and RPM for any given tool and material.

One thing to remember is to make chips not dust. Chips will help by removing the heat produced in the cutting process thus increasing tool life and improving edge quality.

Feed rate is calculated using the following equation:

$$\text{Feed} = N \times \text{cpt} \times \text{RPM}$$

N - number of cutting edges (flutes)

cpt - chip load (chip per tooth) is the amount of material, which should be removed by each tooth of the cutter as it rotates and advances into the work. (mm per tooth)

RPM - the speed at which the cutter revolves in the spindle. (Revolutions per minute) We will now break down the relationship between the Feed rates, number of cutting edges, chip load and RPM. For most materials there is a recommended chip load.

If you are running at 18000 RPM using a 25mm endmill with two flutes, and a recommended chip load of 0.1 mm/tooth:
 $\text{Feed} = 2 \times 0.1 \times 18000 = 3600 \text{ mm per min}$

If the RPM were increased to 24000 RPM the new feed rate would work out to be:
 $\text{Feed} = 2 \times 0.1 \times 24000 = 4800 \text{ mm per min}$

Based on this mathematical equation, as RPM increases, feed rate will also increase if all other settings remain the same. If the number of cutting edges changes, however the feed rate will either increase or decrease depending on the whether the number goes up or down. The same applies to chip load if the recommended chip load is 0.1 mm/tooth the RPM, feed or number of cutting edges may go up or down to maintain the required chip load. Therefore if chip load remains the same, and feed rate increases, either the RPM and or number of cutting edges must increase to maintain the recommended chip load.

When calculating the feed rate for any material the chip load is therefore one of the most important factors to be taken into account because the chip load determines the amount of

No of teeth	cpt (mm)	Feed rate (mm per min) at RPM		
		18000	21000	24000
1	0.1	1800	2100	2400
2	0.1	3600	4200	4800
3	0.1	5400	6300	7200
1	0.4	7200	8400	9600
2	0.4	14400	16800	19200
3	0.4	21600	25200	28800

material that each tooth will remove, plus the load that each tooth will have to take. Another factor that affects chip load is the diameter of the cutter. A larger cutter will be able to handle a larger chip load.

Therefore depending on the diameter of the tool, if the RPM and number of cutter edges stay the same chip load will increase with a larger diameter cutter, thus the feed rate will also increase. When machining softer materials or using a stubby router bit the chip load can be increased. If an extra long router bit is being used, the chip load should be decreased.

For most material that you will be cutting on a MULTICAM router you will typically set the RPM between 18000 and 24000, and adjust your feed rate to obtain the required results. On a MULTICAM router we use spindles that produce a maximum of 24000 RPM. The speeds and feeds chosen can be affected by the horsepower of the spindle being used (horsepower varies from 3Hp to 10 Hp). At higher horsepower you will produce more torque thus allowing the machine to run at a variety of RPM's (torque drops off as the RPM is reduced). For most application

Typical Chip Load Values for Various Size Cutters

Tool Diameter	Hard Woods	Softwood / Plywood	MDF / Particle Board	Soft Plastics	Hard Plastics	Aluminium
3mm	0.08 - 0.13	0.1 - 0.15	0.1 - 0.18	0.1 - 0.15	0.15 - 0.2	0.05 - 0.1
6mm	0.23 - 0.28	0.28 - 0.33	0.33 - 0.41	0.2 - 0.3	0.25 - 0.3	0.08 - 0.15
10mm	0.38 - 0.46	0.43 - 0.51	0.51 - 0.58	0.2 - 0.3	0.25 - 0.3	0.1 - 0.2
12mm & over	0.48 - 0.53	0.53 - 0.58	0.64 - 0.69	0.25 - 0.36	0.3 - 0.41	0.2 - 0.25

we typically work in the 18000 to 22000 RPM range.

Even though there are formulas for calculating feed rates you will find that optimum feed rate will be determined from experience. You will typically start off with the calculated feed rate. Under ideal conditions it is usually suggested that the actual feed rate be set to approximately one-half the calculated amount and gradually increased to the capacity of the machine and the finish desired.

Once you have determined what feed and speed to start with, there are other factors to be taken into consideration. The next thing to be considered is the direction of cut, which is the direction the cutter is fed into the material. Conventional milling or cutting forward is the most commonly used method. With this method the work is fed against the rotation direction of the cutter. The other method is climb milling or cutting reverse. For this machining method the workpiece and the machine must be rigid. The MULTICAM router machine is such a machine. When machining non-ferrous materials, climb cutting should be used to achieve a good finish.

TOOL MATERIAL AND GEOMETRY

Type of End Mill

There are a staggering number of bit manufacturers and designs on the market. Out there somewhere is likely the best bit but the probability of finding it is just about nil. Despite all of these complications it is imperative that the proper bits are found and used. We have found that many bits will often not work at all and others can make a job simple.

Bit's Material Composition

Bits can be made of various grades of steel, various grades of carbide, various types of ceramics, and gemstones. For most practical purposes carbide bits are what most router tables use. Steel bits wear out too fast and the ceramic and gem stone bits cost too much. Even within the carbide category of bits the material will vary in strength and hardness. The stronger the material is, the less likely it is to break. The harder the material the longer the bit will wear. Unfortunately in carbide bits these two features cannot be found in a single bit ... strong bits will not break easily but will get dull quickly, hard ones stay sharp but tend to break quickly.

Number of Flutes

The flutes are the bits cutting edges. It is possible to purchase bits with between 1 and 4 flutes. The number of flutes that you choose depends on the application and cutter design. It will also affect how well the chips are evacuated from the cut. The more flutes used will reduce the space between flutes thus reducing the tools ability to expel the chips.

Cutting Length

This is the cutting length of the end mill. Generally a shorter cutting length is better as they are less likely to break. As a rule, use bits whose cutting lengths are no longer than 3 times the diameter. When using small diameters it is sometimes advisable to go to a "stub" length bit, which has flute lengths only 2 times the diameter of the bit.

Cutting Diameter

This is the cutting diameter of the end mill. Always use the largest diameter allowable.

Cutter Failure

Heat is one of the main causes of cutter edge failure. It is present in all milling operations and is caused by the friction of the cutter and the material coming into contact. Heat cannot be eliminated totally but by using the correct and sharp cutting tools, proper feeds, and speeds for the material being machined, and with proper application of coolant, it can be minimized.

Friction and heat are interrelated, so when dealing with friction you would apply the criteria as heat.

Chipping or crumbling of cutter edges occur when cutting forces impose a greater load on cutting edges that their strength can withstand. Small fractures occur and small areas of the cutting edges chip out. Possible causes of chipping and crumbling.

- i. Excessive feed per tooth
- ii. Poor cutter design
- iii. Running cutter backwards
- iv. Chatter due to a non-rigid condition
- v. Inefficient chip washout
- vi. Built-up edge break away

Built-up edge occurs when particles of the material being cold weld or otherwise adhere to the faces of teeth adjacent to the cutting edges. When this occurs the tool can no longer cut cleanly.

Two other factors to be taken into consideration are rigidity of the table and if coolant will be used. When machining aluminium, coolant should always be applied, if you are to have any success. When it comes to rigidity, if your machine is loose you will not be able to machine at fast feed rates.

Router Table Rigidity

Basically any vibration in the router table's gantry will be transmitted to the tip of the end mill. The faster you go the greater this vibration is amplified and the more likely that you will break the bit because of it. As a general rule the heavier the gantry the better. As you increase cutting speed the gantry at some point will begin to vibrate. At this point you are running too fast for the design of the Router table.

In larger tables, this vibration should only become a factor in larger diameter bits, i.e. greater than 12mm. With smaller bits the speed limitation imposed by other variables will prevent you from reaching the point where it will vibrate. In smaller tables with lighter gantries this vibration will be a limiting factor.

Misting

When cutting metals, a mister is of critical importance. Without it the end mill and/or the chips heat up to the point that the bit will break or the material chips will melt.

Accessories



ISO-30 Tool Holders

with covernut and pull stud for HSD Spindles



ER32 Collets

for HSD Spindles

ER25 Collets

for HSD Spindles
for Elite Spindles



RDO-20 Collets

for Perske Spindles

Solid Carbide Three-Edge Rougher

Application:
For extremely fast routing of hard woods and wood composites.

Primary Use:
Plywood/MDF

Secondary Use:
Hardwoods

PART#	CED	CEL	SHK DIA	OAL
Upcut for Fast Chip Removal				
60-037	9.5mm	28mm	9.5mm	89mm
PCL35411	9.5mm	35mm	9.5mm	89mm
60-051	12.7mm	41mm	12.7mm	101mm

Downcut for Better Hold Down				
60-038	9.5mm	28mm	9.5mm	89mm
60-052	12.7mm	41mm	12.7mm	101mm



Solid Carbide Three-Edge High Helix Rougher

Application:
Unique scalloped cutting edge design for extremely fast routing or hogging.

Primary Use:
Hardwoods

Secondary Use:
Plywood/MDF

PART#	CED	CEL	SHK DIA	OAL
Upcut for Fast Chip Removal				
60-001	9.5mm	28mm	9.5mm	89mm
60-007	12.7mm	41mm	12.7mm	101mm
PCL562274	16mm	55mm	16mm	120mm
60-015	18mm	60mm	18mm	120mm



Solid Carbide Two-Edge Chipbreaker/Finisher

Application:
For faster feed rates than a conventional two flute with a smooth finish.

Primary Use:
Hardwoods/MDF

Secondary Use:
Plywood

PART#	CED	CEL	SHK DIA	OAL
Upcut for Fast Chip Removal				
60-307	9.5mm	28mm	9.5mm	76mm
60-313	12.7mm	41mm	12.7mm	89mm
60-315	12.7mm	55mm	12.7mm	101mm



Solid Carbide Three-Edge Chipbreaker/Finisher

Application:
For additional balance at fast feed rates with a smooth finish.

Primary Use:
Hardwoods and wood composites

Secondary Use:
Plywood/MDF

PART#	CED	CEL	SHK DIA	OAL
Upcut for Fast Chip Removal				
60-337	9.5mm	28mm	9.5mm	76mm
60-351	12.7mm	28mm	12.7mm	76mm
60-353	12.7mm	41mm	12.7mm	89mm



Solid Carbide Two Edge Compression Cutter

Application:
A good quality compression cutter for general use.

Primary Use:
Hardwoods and wood composites

Secondary Use:
Plywood/MDF

PART#	CED	CEL	SHK DIA	OAL	UPCUT LEN
Double Edge					
T2ESRM08	6.35mm	22mm	6.35mm	63mm	8mm
T2ESRM8M	8mm	25mm	8mm	63mm	8mm
T2ESRM10M	10mm	28mm	10mm	75mm	8mm



Solid Carbide High Velocity 4 Flute Upcut

Application:
Combined roughing and finishing cut with upcut cutting action in one tool for rapid feed rates with a good finish.

Primary Use:
Double-Sided Laminated and Veneered Wood Composites, Soft Wood, Hard Wood

PART#	CED	CEL	SHK DIA	OAL
Upcut for Fast Chip Removal				
60-711	12.7mm	28mm	12.7mm	89mm
60-715	12.7mm	41mm	12.7mm	101mm
60-719	12.7mm	55mm	12.7mm	114mm



Solid Carbide Three-Edge Finisher

Application:
Designed for perfect balance and smooth finish over a wide speed range.

Primary Use:
Hardwoods and wood composites

Secondary Use:
Plywood, MDF, Corian, Acrylic, Nylon, HDPE, Polyethylene

PART#	CED	CEL	SHK DIA	OAL
Upcut for Fast Chip Removal				
60-241	6.35mm	22mm	6.35mm	76mm
60-243	9.5mm	15.8mm	9.5mm	76mm
60-245	9.5mm	28.5mm	9.5mm	76mm
60-249	12.7mm	28.5mm	12.7mm	88mm
60-253	12.7mm	41mm	12.7mm	101mm
60-251	12.7mm	54mm	12.7mm	114mm
60-269	19.05mm	41mm	19.05mm	101mm



Solid Carbide **MAXLife** Compression Spiral Cutters

The **MAXLIFE** line of compression spirals are designed for maximum life when cutting MELAMINE, LAMINATED PANELS, or DECORATIVE PLYWOOD.

The **MAXLIFE** tools utilise unique geometries that improve the wear characteristics of the tool under abrasive applications. A unique "maximum wear" carbide was developed and contributes to these tools lasting up to 35% longer than traditional compression tools, while exhibiting superior finish.

PART#	CED	CEL	SHK DIA	OAL	UPCUT LEN
Single Edge					
60-102MW	3.175mm	9.5mm	6.35mm	63mm	5mm
60-106MW	4.76mm	15.8mm	6.35mm	63mm	7.6mm

Double Edge					
60-123MW	9.5mm	22mm	9.5mm	76mm	5mm
60-163MW	12.7mm	22mm	12.7mm	76mm	5mm
60-169MW	12.7mm	28mm	12.7mm	76mm	14mm
60-171MW	12.7mm	35mm	12.7mm	89mm	15.8mm
60-172MW	12.7mm	41mm	12.7mm	89mm	19.05mm
60-196MW	19mm	47.4mm	19mm	102mm	19.05mm

Three-Edge					
60-126MW	9.5mm	22mm	9.5mm	76mm	5mm



Coated Solid Carbide Marathon Compression Spirals

The Marathon Compression cutter is the longest running compression tool due to advancements in cutting geometry and the addition of a unique coating.

The coating creates a tougher cutting edge and protects the edge from high temperatures generated when routing laminated and composite wood products.

PART#	CED	CEL	SHK DIA	OAL	UPCUT LEN
Double Edge					
60-123MC	9.5mm	22mm	9.5mm	76mm	5mm
60-124MC	9.5mm	28mm	9.5mm	76mm	10mm
60-163MC	12.7mm	22mm	12.7mm	76mm	5mm
60-169MC	12.7mm	28mm	12.7mm	76mm	14mm
60-171MC	12.7mm	35mm	12.7mm	89mm	15.8mm
60-172MC	12.7mm	41mm	12.7mm	89mm	19.05mm

Three-Edge					
60-126MC	9.5mm	22mm	9.5mm	76mm	5mm



Special European Single Flute Downcut Spiral Cutters with "O" Flute Geometry

Application:
Designed to rout at incredible feed rates with an outstanding finish.

Primary Use:
Plywood, MDF, hardwoods and wood composites.

Secondary Use:
Acrylic, Nylon and rigid PVC

PART#	CED	CEL	SHK DIA	OAL
Downcut for Better Hold Down				
12010	1mm	4mm	3mm	30mm
12015	1.5mm	6mm	3mm	30mm
12020	2mm	8mm	2mm	30mm
12030	3mm	10mm	3mm	30mm
12030A	3mm	10mm	3mm	60mm
12317	3.175mm	12.7mm	6.35mm	38mm
62-712	3.175mm	12.7mm	6.35mm	50.8mm
12040	4mm	12mm	4mm	50mm
* 12476	4.76mm	15mm	6.35mm	50.8mm
62-718	4.76mm	15mm	6.35mm	50.8mm
12635	6.35mm	19mm	6.35mm	50.8mm
* PCL36396	6.35mm	22mm	6.35mm	63mm
PCL36498	8mm	28mm	8mm	63mm
62-896	8mm	38mm	8mm	76mm
12080A	8mm	38mm	8mm	76mm
62-733	9.5mm	28mm	9.5mm	76mm

* highly recommended



Special European Single Flute Upcut Spiral Cutters with "O" Flute Geometry

Application:
Designed to rout at incredible feed rates with an outstanding finish.

Primary Use:
Plywood, MDF, hardwoods and wood composites.

Secondary Use:
Acrylic, Nylon and rigid PVC

PART#	CED	CEL	SHK DIA	OAL
Upcut for Fast Chip Removal				
13010	1mm	4mm	3mm	30mm
13015	1.5mm	6mm	3mm	30mm
13020	2mm	8mm	2mm	30mm
63-802	2mm	8mm	2mm	50mm
13020A	2mm	8mm	2mm	60mm
63-810	3mm	8mm	3mm	50mm
13030A	3mm	10mm	3mm	60mm
63-814	3mm	12mm	3mm	64mm
63-816	3mm	12mm	6mm	64mm
13317	3.175mm	12.7mm	6.35mm	38mm
63-712	3.175mm	12.7mm	6.35mm	50.8mm
13040	4mm	12mm	4mm	50mm
63-874	4mm	20mm	6mm	64mm
13040G	4mm	22mm	4mm	60mm
63-820	4mm	12mm	4mm	64mm
63-822	4mm	20mm	4mm	64mm
13476	4.76mm	15mm	6.35mm	50.8mm
63-718	4.76mm	15mm	6.35mm	50.8mm
13050	5mm	16mm	5mm	60mm
63-828	5mm	16mm	5mm	64mm
13050A	5mm	30mm	5mm	70mm
13060	6mm	20mm	6mm	60mm
63-838	6mm	20mm	6mm	64mm
13060A	6mm	30mm	6mm	70mm
63-840	6mm	30mm	6mm	76mm
13635	6.35mm	19mm	6.35mm	50.8mm
PCL36395	6.35mm	22mm	6.35mm	63mm
63-726	6.35mm	31mm	6.35mm	76mm
13635-A	6.35mm	38mm	6.35mm	76mm
PCL37061	8mm	28mm	8mm	63mm
63-846	8mm	38mm	8mm	76mm
13080	8mm	22mm	8mm	60mm
13080A	8mm	38mm	8mm	80mm
63-733	9.5mm	28mm	9.5mm	76mm
63-848	10mm	30mm	10mm	76mm
63-849	10mm	35mm	10mm	76mm
13100	10mm	30mm	10mm	76mm
13120	12mm	30mm	12mm	76mm



HSD Spindles and Aggregates

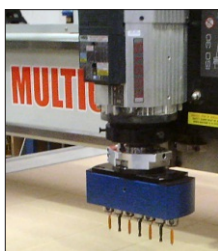

Solid Carbide Single Edge Straight Cutters

Application:
An economical single flute general purpose straight cutter.

Primary Use:
Plywood, MDF, hardwoods and wood composites.

Secondary Use:
Most materials

PART#	CED	CEL	SHK DIA	OAL
T202-S	1.6mm	5mm	6.35mm	38mm
T202-MS	2mm	5mm	6.35mm	38mm
* PCT36092	2.38mm	6.35mm	6.35mm	50mm
T1804-S	3.175mm	12.7mm	6.35mm	57mm
T1804-MS	4mm	16mm	6mm	57mm
T1806-S	4.76mm	19mm	6.35mm	57mm
T1805-MS	5mm	19mm	6.35mm	57mm
T1806-MS	6mm	22mm	6.35mm	57mm
T1808-S	6.35mm	25.4mm	6.35mm	57mm

* O Flute



Plunge Routing Tools

Application:
High speed plunge routing tool for camlock and hinge holes

Primary Use:
Kitchen and cabinet manufacture.

PART#	CED	CEL	SHK DIA	OAL
DPL2030-16	20mm	30mm	16mm	95mm
* DPL3530-16	35mm	30mm	16mm	95mm
DPP4012-16	40mm	12mm	16mm	76mm

* three edge



Replacement blades

available as single purchase or boxes of 10

CUTTER	CENTER BLADE	OUTER BLADE
DPL2030-16	10.5x10.5x1.5	30x0.9x1.5EC
DPL3530-16	V10.6x12x1.5	30x12x1.5EC
DPP4012-16	N/a	20x12x1.5EC

Solid Carbide Double Edge Cutters

Application:
An economical two flute general purpose straight cutter.

Primary Use:
Plywood, MDF, hardwoods and wood composites.

Secondary Use:
Most materials

PART#	CED	CEL	SHK DIA	OAL
* 56-430	4mm	16mm	6mm	64mm
* 56-431	5mm	20mm	6mm	64mm
* 56-432	6mm	25mm	6mm	64mm
56-330	9.5mm	28mm	12.7mm	76mm
56-360	12.7mm	28mm	12.7mm	76mm
56-654	12.7mm	44mm	12.7mm	101mm

* O Flute

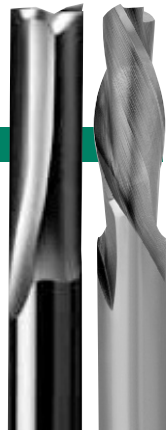

Surface Planing Tools

Application:
Rapid planing of wide surfaces

Primary Use:
MDF, some hardwoods and plastics

PART#	CED	CEL	SHK DIA	OAL
* DPP4012	40mm	12mm	16mm	76mm
** DPP5512	55mm	12mm	12.7mm	65mm

* two edge (recommended)

** not compatible with some tool changers due to diameter

Replacement blades

available as single purchase or boxes of 10

Tool	Center Blade	Outer Blade
DPP4012	N/a	20x12x1.5 EC
DPP5512	N/a	V12x12x1.5



DPP4012



DPP5512

Double Edge Spiral Downcut for Better Hold Down

57-910	6.35mm	22mm	6.35mm	63mm
57-923	9.5mm	28mm	9.5mm	76mm
57-365	12.7mm	41mm	12.7mm	88mm

Core Box Cutters



Application:
Panel doors and decorative edge, molds and grooving.

Primary Use:
MDF, hardwoods, plywoods and wood composites

PART#	CED	CEL	SHK DIA	OAL
T306	4.76mm	11mm	6.35mm	38mm
T412	9.5mm	6.35mm	6.35mm	31mm
T416-1/2	12.7mm	8.7mm	12.7mm	57mm
T420-1/2	15.9mm	9.5mm	12.7mm	57mm
T424-1/2	19mm	12.7mm	12.7mm	57mm
T432-1/2	25.4mm	12.7mm	12.7mm	57mm
T440-1/2	31.8mm	19mm	12.7mm	63mm
T448-1/2	38mm	22mm	12.7mm	67mm

Range of Traditional and Profile cutters.



Application:
Panel doors and decorative edge molds, grooving and rounding over

Primary Use:
Plywood, MDF, hardwoods and wood composites.

PART#	CED	CEL	SHK DIA	OAL
TTC 8 1/2	17.4mm	12.7mm	12.7mm	57mm
TTC 16 1/2	29.3mm	16mm	12.7mm	57mm



Core box bit



Traditional classic bit

Specially Designed Engraving Tools

Application:
These specially designed engraving tools are manufactured from micrograin carbide for fine engraving with long tool life.

Primary Use:
Engraving laminate materials



PART#	TIP DIA	SHK DIA	OAL	DEG
GR94161	0.1mm	3mm	30mm	60
GR92176	0.1mm	6mm	60mm	90
GR91097	0.4mm	6mm	60mm	60
GR91101	0.5mm	6mm	60mm	30

Shelf Hole Bits



Bits for drilling shelf holes.

PART#	CED	CEL	SHK DIA	OAL
TX1804.9MS	4.9mm	19mm	6.35mm	76.2mm
TX1805MS	5mm	19mm	6.35mm	76.2mm

Dowell Drill Bits



Drills specifically designed to drill laminate board without breakout. Typically used in multi spindle gang drill heads.

PART#	CED	CEL	SHK DIA	OAL
WD4R56	4mm	27mm	10mm	56mm
WD5L56	5mm	27mm	10mm	56mm
WD5R56	5mm	27mm	10mm	56mm
WD5L70	5mm	35mm	10mm	70mm
WD5R70	5mm	35mm	10mm	70mm
WD8L56	8mm	27mm	10mm	56mm
WD8R56	8mm	27mm	10mm	56mm
WD10L56	10mm	27mm	10mm	56mm
WD10R56	10mm	27mm	10mm	56mm
WD35R56*	35mm		10mm	56mm

* Hinge boring bit

L= left hand, R = right hand

Contact us for a list of decorative edge, rounding over and drawer pull bits.

CUSTOMISED CNC ROUTERS AND ROUTING SOLUTIONS



Sometimes a standard solution won't be ideal for your business or application. Being an Australian manufacturer we can custom make a machine to meet your exact requirements.

Extra length, extra width, extra attachments, Australian made Multicam CNC routers fit the bill.

To ensure reliability of operation and long service life, we use only the best components and attachments sourced from leading manufacturers around the world.

You gain from our knowledge and experience gained from over 30years' of experience in CNC routing machinery.



We can provide bespoke solutions for whatever your needs may be. From customised work holding and clamping devices to material loading, positioning and unloading attachments, we work closely with you to ensure that your machine performs exactly as required.

"V" Groove Cutters

Application:
3D engraving or decorative vee grooves and chamfers in wood and wood composites, MDF, hardwoods, plywood, ductboard, acrylic and plastics.

Replaceable Insert Type

Replaceable insert cutters offer the advantage of being less expensive to run over their lifespan. The cutting blades are replaceable and often double sided providing two cutting edges on each blade.



PART#	MAX DIA	MAX DEPTH	SHK DIA	OAL	DEG
DV45-40	40mm	40mm	12.7mm	90mm	45
DV60-16	20mm	16mm	12.7mm	70mm	60
DV90-16	36mm	16mm	12.7mm	70mm	90
DV90-34	70mm	34mm	20mm	70mm	90
DV90-88	88mm	45mm	20mm	110mm	90
DV120-10	36mm	10mm	12.7mm	70mm	120

Cemented Carbide Type

Cemented carbide cutters a disposable style cutter and are a cost-effective alternative choice for grooving. They perform exceptionally well and are often available in sizes not available in replaceable insert styles.



PART#	MAX DIA	MAX DEPTH	SHK DIA	OAL	DEG
T6128	25mm	22mm	6.35mm	57mm	60
T6128 1/2	25mm	22mm	6.35mm	70mm	60
* T112WF	18mm	7.5mm	6.35mm	45mm	90
T112	18mm	9mm	6.35mm	45mm	90
T128	31mm	15mm	6.35mm	50.8mm	90
T128 1/2	31mm	15mm	12.7mm	63.5mm	90
T1230 1/2	39mm	20mm	12.7mm	86mm	90
T1236 1/2	45mm	22mm	12.7mm	81.5mm	90
*** T1240 1/2	50.8mm	25.4mm	12.7mm	76mm	90
** TV90WF	31mm	10.5mm	12.7mm	60mm	90
TV1232	25.4mm	7.5mm	6.35mm	43mm	120
TV1264 1/2	50.8mm	14.5mm	12.7mm	73mm	120

* with 3mm flat

** with 10mm flat

*** not compatible with some tool changers due to diameter

Solid Carbide Type

A disposable style cutter and are a cost-effective alternative choice for grooving. They perform exceptionally well and are often available in sizes not available in replaceable insert or cemented carbide styles. These cutters have a 0.5mm flat on their tip.



PART#	MAX DIA	MAX DEPTH	SHK DIA	OAL	DEG
TV2208	6.35mm	14mm	6.35mm	57mm	22.5
TV2216 1/2	12.7mm	30mm	12.7mm	76mm	22.5
TV3008	6.35mm	10mm	6.35mm	57mm	30
TV3016 1/2	12.7mm	22mm	12.7mm	76mm	30
TV4508	6.35mm	7mm	6.35mm	57mm	45
TV4516 1/2	12.7mm	14mm	12.7mm	76mm	45

Replacement V groove cutter blades

available as single purchase or boxes of 10

CUTTER	BLADE/INSERT
DV45-40	V45 50X12
DV60-16	V60 20X12
DV90-16	V90 30X12
DV90-34	V45 50X12
DV90-88	DV90-88 Insert set of 2
DV120-10	v120 20x12x1.5

Solid Carbide Ball Nose Cutter

Application:

For grooving panel designs such as cupboard doors.

Primary Use:

MDF, ACM, hardwoods, and most timbers

Secondary Use:

High density foams and model makers' wax

PART#	CED	CEL	SHK DIA	OAL
52-240BM	3mm	12mm	6mm	50mm
52-280BM	6mm	22mm	6mm	64mm
TSRWB8	6.35mm	19mm	6.35mm	63mm
52-280B	6.35mm	22mm	6.35mm	63mm
52-320B	9.5mm	28mm	9.5mm	76mm
52-320BM	10mm	29mm	10mm	76mm
52-360BM	12mm	29mm	12mm	76mm
52-360B	12.7mm	28mm	12.7mm	76mm



Solid Carbide Ball Nose Cutters

Application:

For model making and 3 dimensional surface applications.

Primary Use:

High density foam and model makers' wax.

Secondary Use:

MDF and most timbers

PART#	CED	CEL	SHK DIA	OAL
SCB3	3mm	7mm	6mm	57mm
SCB6	6mm	10mm	6mm	57mm
TSRWB8	6.35mm	19mm	6.35mm	63mm
SCB1/4	6.35mm	19mm	6.35mm	63mm
SCB8	8mm	16mm	8mm	63mm
SCB9.5	9.5mm	22mm	9.5mm	63mm
SCB10	10mm	19mm	10mm	72mm
SCB12	12mm	25mm	12mm	84mm
SCB12.7	12.7mm	25mm	12.7mm	76mm



Single Flute Straight Cutters with Special "O" Flute Geometry

Application:
Designed to rout at fast feed rates with a very smooth finish.

Primary Use:
Acrylic and polycarbonate. Suitable for material 2mm to 18mm

Secondary Use:
Wood composites, corflute



PART#	CED	CEL	SHK DIA	OAL
* PCT36092	2.38mm	6.35mm	6.35mm	50mm
* 61-041	3.175mm	8mm	6.35mm	50.8mm
61-042	3.175mm	12mm	6.35mm	50.8mm
PCT582109	3.175mm	15mm	6.35mm	50.8mm
* PCT35491	4mm	8mm	6.35mm	50.8mm
PCT35513	4mm	12.7mm	6.35mm	50.8mm
# 56-430	4mm	16mm	6mm	64mm
61-061	4.76mm	9.5mm	6.35mm	50.8mm
* 61-062	4.76mm	16mm	6.35mm	50mm
# 56-431	5mm	20mm	6mm	64mm
# 56-432	6mm	25mm	6mm	64mm
* 61-082	6.35mm	19mm	6.35mm	63.5mm
61-085	6.35mm	25mm	6.35mm	82mm
61-122	9.5mm	23mm	9.5mm	65mm
61-414	8mm	25mm	8mm	64mm

* highly recommended
double flute cutter

D Cutter

Application:
Tapered bit for cutting acrylic & rigid PVC up to 6mm thick. 14deg included angle.

PART#	CED	CEL	SHK DIA	OAL
Dcutter	3.175mm	6mm	3.175mm	38mm



Special European Single Flute Upcut Spiral Cutters with "O" Flute Geometry

Application:
Designed to rout at high feed rates with an outstanding.

Primary Use:
Acrylic, rigid PVC. Suitable for material 4.5mm to 35mm

Secondary Use:
Wood composites, MDF, hardwoods, plywood. High pressure laminates



PART#	CED	CEL	SHK DIA	OAL
Upcut for Fast Chip Removal				
13010	1mm	4mm	3mm	30mm
13015	1.5mm	6mm	3mm	30mm
13020	2mm	8mm	2mm	30mm
63-802	2mm	8mm	2mm	50mm
13020A	2mm	8mm	2mm	60mm
63-810	3mm	8mm	3mm	50mm
13030A	3mm	10mm	3mm	60mm
63-814	3mm	12mm	3mm	64mm
63-816	3mm	12mm	6mm	64mm
13317	3.175mm	12.7mm	6.35mm	38mm
63-712	3.175mm	12.7mm	6.35mm	50.8mm
13040	4mm	12mm	4mm	50mm
63-820	4mm	12mm	4mm	64mm
63-874	4mm	20mm	6mm	64mm
63-924	4mm	20mm	6mm	64mm
63-874	4mm	20mm	6mm	64mm
PCL583034	4mm	30mm	4mm	64mm
63-822	4mm	20mm	4mm	64mm
63-718	4.76mm	15mm	6.35mm	50.8mm
13476	4.76mm	15mm	6.35mm	50.8mm
13050	5mm	16mm	5mm	60mm
63-828	5mm	16mm	5mm	64mm
13050A	5mm	30mm	5mm	70mm
PCL583281	5mm	30mm	5mm	64mm
13060D	6mm	22mm	6mm	60mm
13060E	6mm	32mm	6mm	70mm
63-938	6mm	20mm	6mm	64mm
13635	6.35mm	19mm	6.35mm	50.8mm
PCL36395	6.35mm	22mm	6.35mm	63mm
63-726	6.35mm	31mm	6.35mm	76mm
13635-A	6.35mm	38mm	6.35mm	76mm
13080	8mm	22mm	8mm	60mm
13080A	8mm	38mm	8mm	80mm
PCL37061	8mm	28mm	8mm	63mm
63-846	8mm	38mm	8mm	76mm
13100	10mm	30mm	10mm	75mm
63-848	10mm	30mm	10mm	76mm
63-849	10mm	35mm	10mm	76mm
13120	12mm	30mm	12mm	75mm

Special European Single Flute Downcut Spiral Cutters with "O" Flute Geometry

Application:
Designed to rout at high feed rates with an outstanding.

Primary Use:
Acrylic, rigid PVC. Suitable for material 4.5mm to 35mm

Secondary Use:
Wood composites, MDF, hardwoods, plywood.



PART#	CED	CEL	SHK DIA	OAL
Downcut for Better Hold Down				
12010	1mm	4mm	3mm	30mm
12015	1.5mm	6mm	3mm	30mm
12020	2mm	8mm	2mm	30mm
12030	3mm	10mm	3mm	30mm
12030A	3mm	10mm	3mm	60mm
12317	3.175mm	12.7mm	6.35mm	38mm
62-712	3.175mm	12.7mm	6.35mm	51mm
12040	4mm	12mm	4mm	30mm
* 12476	4.76mm	15mm	6.35mm	50.8mm
62-840	6mm	30mm	6mm	76mm
* 12635	6.35mm	19mm	6.35mm	50.8mm
PCL36396	6.35mm	22mm	6.35mm	63mm
PCL36498	8mm	28mm	8mm	63mm
# 62-846	8mm	38mm	8mm	76mm
** 62-896	8mm	38mm	8mm	76mm
62-733	9.5mm	28mm	9.5mm	76mm
62-848	10mm	30mm	10mm	76mm

* highly recommended

** for soft plastics

for hard plastics

Solid Carbide Single Edge Straight Cutters

Application:
An economical single flute general purpose straight cutter.

Primary Use:
Most plastics

Secondary Use:
Plywood, MDF, hardwoods and wood composites.



PART#	CED	CEL	SHK DIA	OAL
T202S	1.6mm	5mm	6.35mm	38mm
T202MS	5mm	5mm	6.35mm	38mm
T1804-S	3.175mm	12.7mm	6.35mm	57mm
# 56-430	4mm	16mm	6mm	64mm
T1806-S	4.76mm	19mm	6.35mm	57mm
# 56-431	5mm	20mm	6mm	64mm
T1806-MS	6mm	22mm	6.35mm	57mm
# 56-432	6mm	25mm	6mm	64mm
T1808-S	6.35mm	25.4mm	6.35mm	57mm
56-654	12.7mm	44mm	12.7mm	101mm

double flute cutter

Solid Carbide Saw Flush Mount



Application:
Small diameter arbor mounted saws. Saws are permanently mounted to arbors and are not reversible.

Primary Use:
Trimming and slotting plastics

Secondary Use:
Nil

PART#	CED	WIDTH	SHK DIA	OAL	ROTATION
70-204	25.4mm	1.58mm	12.7mm	101mm	Right Hand
70-224	31mm	1.58mm	12.7mm	101mm	Right Hand
** 70-320	50.8mm	2.4mm	12.7mm	101mm	Right Hand
# 70-360	50.8mm	2.4mm	12.7mm	101mm	Right Hand

for hard plastics

** for soft plastics

Solid Carbide Foam Cutters

Application:
Routing polystyrene foam

PART#	CED	CEL	SHK DIA	OAL
52-554	3.175mm	28mm	6.35mm	64mm
52-564	6.35mm	57mm	6.35mm	90mm
TSF8	6.35mm	57mm	6.35mm	101mm
TSF12 3/8	9.5mm	57mm	9.5mm	101mm



TSF series

Did you know?

Not all foams can be routed!

See next page for a range of oscillating and drag knife blades suitable for cutting softer foams such as insulation foams, packing foams etc.

Solid Carbide Up Spiral Cutters with Small Cut Diameters

Application:
For cutting 1mm to 3mm aluminium, brass or copper when a small diameter cutter is required

Primary Use:
Non-ferrous metals

Secondary Use:
Wood composites and fibreglass

PART#	CED	CEL	SHK DIA	OAL
2FS-1.0	1.0mm	5mm	3.175mm	40mm
2FS-1.2	1.2mm	5mm	3.175mm	40mm
2FS-1.5	1.5mm	6mm	3.175mm	40mm
2FS-2.0	2.0mm	8mm	3.175mm	40mm
2FS-2.5	2.5mm	8mm	3.175mm	40mm
2FS-3.0	3.0mm	10mm	3.175mm	40mm
52-040	3.175mm	12.7mm	6.35mm	50mm
52-060	4.76mm	15.8mm	6.35mm	50mm



Solid Carbide Up Spiral Cutters with Geometry for cutting metals at fast feed rates.

Application:
For cutting 3mm to 12mm aluminium. Produces a very smooth edge with very good chip removal

Primary Use:
Non-ferrous metals

Secondary Use:
Wood composites, laminates and some ferrous metals

PART#	CED	CEL	SHK DIA	OAL
63-904	2mm	6mm	6mm	64mm
33030	3mm	8mm	3mm	30mm
63-912	3mm	8mm	6mm	64mm
63-916	3mm	12mm	6mm	64mm
63-606	3.175mm	6.35mm	6.35mm	50mm
** 63-610	3.175mm	12.7mm	6.35mm	50mm
63-918	4mm	8mm	4mm	64mm
33040	4mm	12mm	3mm	60mm
** 63-924	4mm	20mm	6mm	64mm
* 63-614	4.76mm	9.5mm	6.35mm	50.8mm
63-618	4.76mm	16mm	6.35mm	50.8mm
33050	5mm	16mm	5mm	60mm
63-930	5mm	16mm	6mm	64mm
63-934	6mm	8mm	6mm	64mm
33060	6mm	15mm	6mm	50mm
* 63-938	6mm	20mm	6mm	64mm
63-620	6.35mm	9.5mm	6.35mm	50.8mm
* 63-622	6.35mm	19mm	6.35mm	63.5mm
63-629	7.94mm	17mm	7.94mm	64mm
063810	8mm	10mm	8mm	60mm
63-946	8mm	38mm	8mm	76mm
63-948	10mm	30mm	10mm	76mm



D Cutter

Application:
Tapered bit for cutting or engraving brass. 14deg included angle.

Primary Use:
Brass, acrylic, rigid PVC up to 6mm thick.

Secondary Use:
MDF, acrylic and wood

PART#	CED	CEL	SHK DIA	OAL
Dcutter	3.175mm	6mm	3.175mm	38mm



Downcut for Better Hold Down

*** 62-606	3.175mm	6.35mm	6.35mm	50mm
*** 62-614	4.76mm	9.5mm	6.35mm	50mm

* highly recommended

** highly recommended for cutting 1mm to 3mm Aluminium when a small cut diameter is required

*** highly recommended for cutting 1mm to 2mm Aluminium with a downward cut when a small cut diameter is required

Did you know?

Mist sprayer and cold air gun attachments greatly increase tool life and cut edge quality by reducing heat associated with metal cutting.

These devices can be retrofitted to most CNC machines.

High Performance Composite Router

Application:
Designed to machine exotic composite materials & fibreglass.
Coated AlTiN
(not suitable for ACM)



PART#	CED	CEL	SHK DIA	OAL
66-915AlTiN	6.35mm	38mm	6.35mm	76mm
* TG8	6.35mm	19mm	6.35mm	76mm
* TG8 endcut	6.35mm	19mm	6.35mm	76mm
66-923AlTiN	9.5mm	25mm	9.5mm	76mm
66-931AlTiN	9.5mm	54mm	9.5mm	102mm
66-935AlTiN	12.7mm	28mm	12.7mm	76mm
66-943AlTiN	12.7mm	54mm	12.7mm	102mm

* uncoated

Specially Designed Solid Carbide cutters for V grooving Alucobond/Alpolic and similar composite materials

Application:
These French designed cutters are used when V groove routing ACM and similar composite materials.

Primary Use:
Alucobond/Alpolic

Secondary Use:
Composite materials Seadek



PART#	CED	D1	D2	ANGLE	OAL
99168	19mm	9.5mm	2mm	135	70mm
99167	19mm	9.5mm	3mm	90	70mm
99166	20mm	8mm	2mm	135	70mm
99165	20mm	8mm </td <td>3mm</td> <td>90</td> <td>70mm</td>	3mm	90	70mm

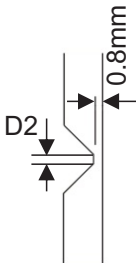
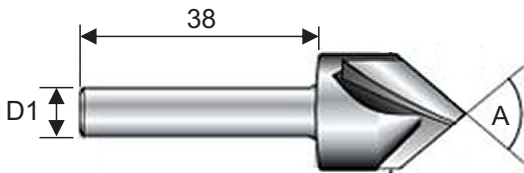

M30-890 8mm Shank 90deg Vee, 3mm flat
M41-290 12mm Shank 90deg Vee, 3mm flat
M41-235 12mm Shank 135deg Vee, 3mm flat
 highly recommended for solid core ACM

Blades for Multicam Tangential and Oscillating Knives

Application:
Cutting of Foams, Cardboard, X-Board, Coreflute, Ductboard etc

PART#	CEL	BLADE TYPE	OAL
-------	-----	------------	-----

Double point - for cutting foams, fibrous and insulation material

BT56240	40mm	Double	70mm
BT56265	65mm	Double	95mm
BT562090	90mm	Double	120mm

Round point - for cutting Dense Foam, Cardboard, Corflute, Rubber, Acoustic Mat.

BT57275	6mm	Single	36mm
BT57267	12mm	Single	42mm
BT57265	15mm	Single	45mm
BT57268	25mm	Single	55mm
BT57269	30mm	Single	60mm
BT572050	50mm	Single	80mm
BT572065	65mm	Single	95mm
BT57270	70mm	Single	100mm
BT57290	90mm	Single	120mm

Flat point - for cutting fibrous and insulation materials.

BT57220	20mm	Single	50mm
BT57230	30mm	Single	60mm
BT572070	70mm	Single	100mm
BT56290	90mm	Single	120mm
BT572110	110mm	Single	140mm
BT572120	120mm	Single	150mm



Sabre blade for cutting Dense Foam, Cardboard, Corflute, Polypropolene.

BT2362	double end	60 deg	50mm
BT2392	double end	90 deg	50mm
* BT13899	single end	60 deg	50mm

* 14mm cut depth



1/2" Polycrystalline Diamond (PCD) Tipped Single Flute Mortise Compression

Application:
Designed to rout composite materials or materials with hard substrates.

Primary Use:
Wood composites, abrasive materials

PART#	CED	CEL	SHK DIA	OAL
68-101	9.5mm	25.4mm	12.7mm	76mm
68-102	12.7mm	25.4mm	12.7mm	76mm





TRIDENT™

CNC Cutting Machines

HIGH-SPEED AUTOMATION FOR POINT OF SALE AND DISPLAY



scan to see
me in action

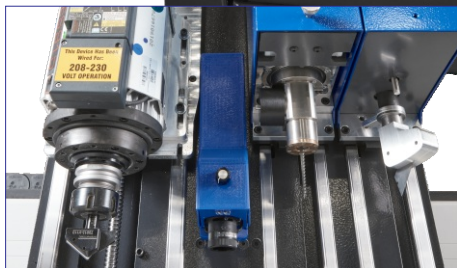

A TOOL FOR EVERY JOB

Trident CNC cutting machines feature cutting solutions for all substrates. Heavy duty routing spindle, oscillating knife head and tangential knife head allow for cutting, knifing and creasing, all with camera recognition.

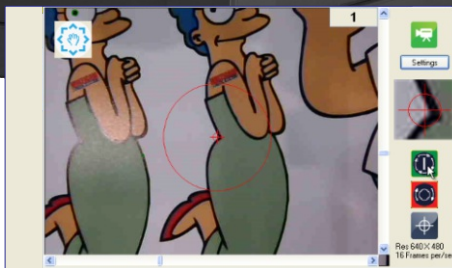

CAMERA REGISTRATION

The Multicam Vision System uses printed registration marks on your job to adjust the cutting program for perfect alignment. This essential option for print-to-cut applications works with all cutting tools and materials.



LIVE DECK VACUUM ZONES

All Trident machines include Live Deck vacuum switching. This innovative system activates and deactivates vacuum zones according to the current position of the machine cutting head providing greater work holding.

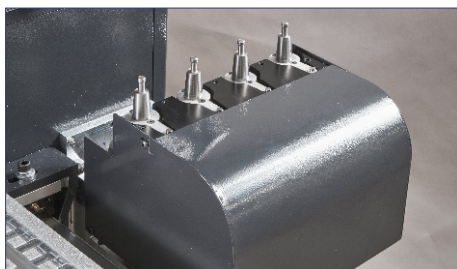

AUTOMATIC KNIFE TOOL CHANGER

The Optional Tangential knife tool changer will ensure your machine keeps running without operator input. Simply program jobs to use multiple tangential knife attachments and the Trident will automatically change tools as required.

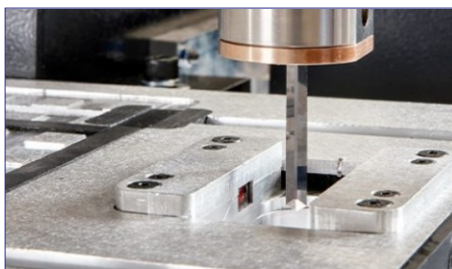

KNIFE TOOL CALIBRATOR

The automatic calibrator measures the knife blade length. Qualifying the knife blade automatically eliminates the need for manual setup, a huge time-saver. This new feature also precisely detects and corrects the blade angle.

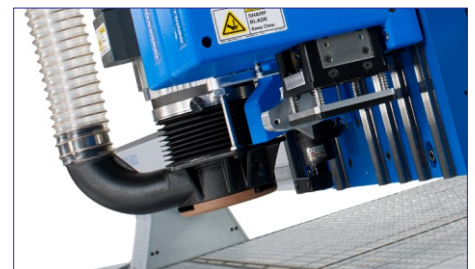

DUST EXTRACTION

Our unique micro filter dust extraction system, combined with pressure foot, provides filter density of up to 0.05 microns, which is up to 7 times greater filter area when compared to a standard extraction system.

TANGENTIAL KNIFE HEAD ATTACHMENTS

Attachments for Tangential heads that provide cutting and creasing solutions for a variety of products including cardboard, X board, corflute, foams and similar products.

Box Cutters



Creasing Wheels



45 Degree Box Cutters

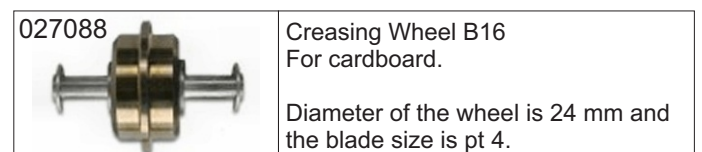
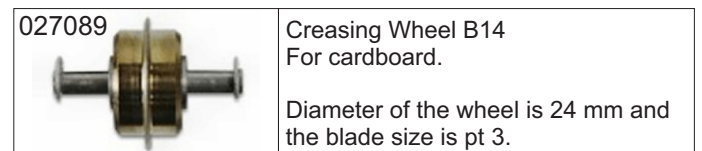
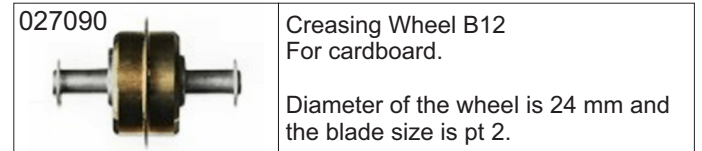

Replacement Box Cutter Blades

KB03018	1.0mm	Box of 5
KB61329	0.9mm	Box of 5

Sabre Blade Cutters

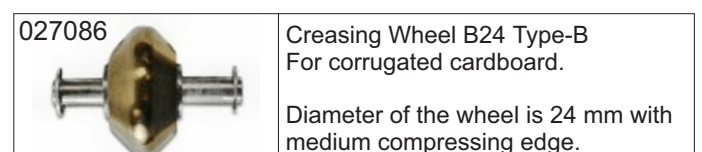
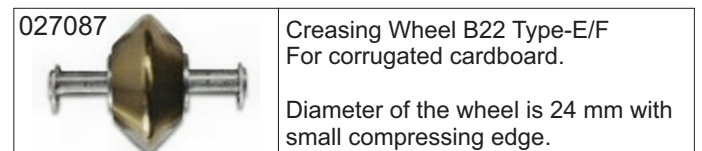

For cutting Dense Foam, Cardboard, Corflute, Polypropylene

Replacement Sabre Blades

BT2362	double end	60 deg	50mm
BT2392	double end	90 deg	50mm
BT13899	single end	60 deg	50mm 14mm cut depth

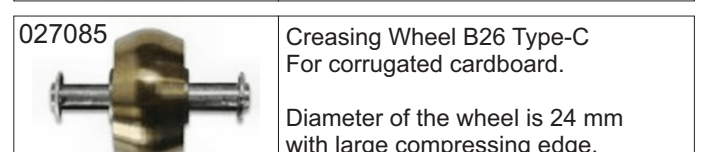

Rotary Blade Cutters

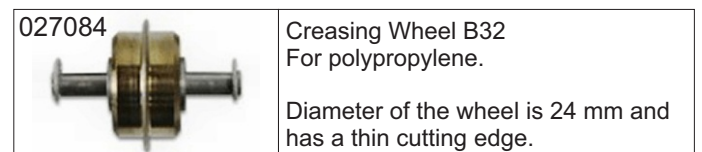

EDUCATIONAL AND TRADE TRAINING PARTNERS

Multicam CNC Routing machines are used in Schools, Universities, Colleges and Trade training institutions throughout Australia.

Adelaide Botanic High School - SA
Adelaide Hills Trade Training Centre - SA
Adelaide University - SA
Aldinga B12 School - SA
Australian Catholic College - NSW
Australian Institute of Sport - ACT
Australian National University - College of Fine Arts - ACT
Australian Synchrotron - ACT
Australian Technical College - Bendigo, Vic
Australian Technical College - Hunter, NSW
Bacchus Marsh Grammar School - Vic
Ballarat & Queens's Anglican Grammar - Vic
Barker College - Furniture & Design Technology Department - NSW
Bendigo Tech School - La Trobe University - Vic
Bond University - Qld
Burgmann Anglican School - Faculty of Design Technology - ACT
C.S.I.R.O - Vic
Canberra Grammar School - NSW
Cap Education - Qld
Carey Baptist College - WA
Catholic Regional College Sydenham - Vic
Cedar College - SA
Chairo Christian School - Vic
Chisholm Institute of TAFE Dandenong - Woodworking Department - Vic
Cranbourne West Secondary College - Vic
Curtin University of Technology - WA
Deakin University - Carbon Nexus - Vic
Deakin University - Faculty of Science and Technology - Vic
Edith Cowan University - WA
Edenbrook Secondary College - Vic
Educational Writing Boards
Faith Christian School of Distance Education - Qld
Federation Training - Vic
Geelong Grammar School - Vic
Glasshouse Country Christian College - Qld
Goulburn Ovens Institute of TAFE - Wangaratta - Vic
Goulburn Ovens Institute of TAFE - Werribee - Vic
Greater Shepparton Secondary College - Vic
Griffith University - Southport - Qld
Griffith University - Nathan Campus - Qld
Hallam Senior College - Vic
Hamilton Secondary College - Training Campus- SA
Highfields Secondary College - Qld
Highview Christian Community College - Vic
Iona College - Faculty of Industrial Design & Technology - Qld
Ipswich State High School - Qld
John Paul College - NSW
Kennedy Baptist College - WA
Kings Christian College - Qld
La Salle College - WA
Lake Tuggeranong College - Trade Training - ACT
Lidcome TAFE - NSW
MacKillop College - NSW
Macquarie University Dept of Engineering - NSW
Macquarie University Dept of Science - NSW
Make Models - NSW
Mazenod College - WA
McClelland College - Vic
Melbourne Grammar School - Vic
Mernda Central College - Vic
Moriah College - NSW
Nazareth College - Vic
New Norfolk High School - Materials, Design & Technology Dept - Tas
Newhaven College - Vic
Northland Secondary College - Vic
Point Cook College - Vic
Port Hacking High School - NSW
Queensland University of Technology - Faculty of Architecture, Interior & Industrial Design - Qld
Riverland B12 College - SA
RMIT University - School of Aerospace, Mechanical & Manufacturing Engineering - Vic
Rockhampton State High School - Qld
Scotch Oakburn College - Tas
Sheldon College - Qld
Southern Cross University - Qld
Southwest Institute of Technology - WA
St Columba Anglican School - NSW
St Columban's College - Qld
St Edmunds College - Qld
St Ignatius College Riverview - NSW
St James College - Qld
St Joesphs College - Qld
St Mary Mackillop College - NSW
St Mary's Cathedral College - NSW
St Mary's Catholic College - NSW
St Michaels College - Qld
St Patricks College - Tas
St Paul's School - Qld
St Thomas More College - Qld
Studentworks Launceston - Tas
Swinburn University of Technology - Vic
Sydney Grammar School - NSW
TAFE Hunter Institute Maitland - Signwriting & Industry faculty - NSW
TAFE NSW Riverina Institute - NSW
TAFE Queensland - Qld
The Cathedral College - Qld
The King's School - NSW
Ultimo TAFE - NSW
University of Canberra - ACT
University of Canberra SSC - ACT
University Of Melbourne - Engineering - Vic
University of Melbourne - Gratten St - Vic
University Of Newcastle - NSW
University of NSW - College of Fine Arts
University of NSW - Faculty of Building Environment
University of NSW - School of Mechanical & Manufacturing Engineering
University Of Queensland - Qld
University Of South Australia - SA
University of Sydney - NSW
University Of Tasmania - Tas
University Of Technology Sydney - NSW
University of Western Australia - WA
Unley High School - SA
Upper Coomera State College - Qld
Urbrae Agricultural High School - AS
Victoria University of Technology - Vic
Vincentia High School - NSW
Wesley College - Vic
Westminster School - SA
Wollondilly Anglican College - Qld

MULTICAM MACHINE OPTIONS



Multicam Vision System (MVS)

The primary application of the MVS system is digital print finishing where the camera is used to quickly locate registration marks and adjust the machine cutting path to achieve exact alignment with the printed shapes. It includes non-linear/linear distortion, skew and rotation correction.



Multi Spindle "L shaped" Drill Head

Fully independent X/Y axis drilling head used primarily in the Kitchen and Cabinetmaking industries, a number of system 32 holes are able to be produced in a single Z movement of the head. Various number of configurations are available.



7 or 11 Straight Multi Drill Head

These straight style drill head attachments are available with centres of 25mm, 32mm and 50mm allowing you to choose the unit that matches your requirements. Ideally suited to applications where large numbers of holes are required on a board.

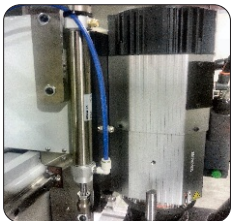

Air Assisted Surface to Depth System.

The surface to depth system is essential to ensure a constant cut depth into material. It compensates for variations in the material thickness. Used mainly when routing pencil round edges, OR V-Grooving Aluminium-Polymer composite material.



Multiple Head Systems

Multiple head systems, available in any configuration, allow for greater flexibility in processing a wide variety of materials in a single, uninterrupted operation. Print and Cut, Rout and Knife, Rout and Drill operations are just a few examples.



Tangential Knife and Creasing Wheel

The oscillating tangential knife can be fitted with attachments ranging from straight knife blades, angled knife blades to "pizza" and creasing wheels for cutting or creasing a variety of materials including foams, card boards and matting materials.



KitchenCAD Pro Software

An easy to use parametric cabinet solution for Cabinet makers. Operators can quickly and easily create any standard cupboard unit including wall oven towers, or change any pre-defined attributes of a design. It also supports standard assembly types including mortise and tenon. Door Wizard, and True shape nesting are standard.

Automatic Tool Changers

Fully Automatic Tool Changers are ideal where you have processes that requires multiple tools for complex profiles, routing and boring. Their automatic operation increases productivity by eliminating operator intervention during cutting.



Pop Up Pins and Side Locators

Automatic pop up pins and side locators enable you to quickly position material on the machine bed. Once processing has commenced they automatically retract providing a totally clear bed surface and eliminate the need for fixed locators.



Automatic Material Loader

Designed to automatically pick sheet material from an indexing material lifter and place it on the machine bed ready for cutting. Ideal for high production environments or where OH&S issues arise due to manual handling of heavy sheets.



Material Handling Systems

Combine the conveyor off loading table with the Automatic indexing table and material loader you have a fully automatic material handling solution for your factory. Very popular in Nested Based Manufacturing situations and where large heavy materials are used.



Micro-Air Extraction Systems

The latest technology in efficient swarf removal. Designed for all types of material, and featuring a pleated filter and plastic dust bag contained in sealed canisters. This reduces toxic, hazardous dust in the air to 0.03microns. A spare roll out bin makes removing a full bag quick and easy.



Mist Sprayers

When cutting ferrous and non ferrous materials cooling and lubricating of the cutter edge is critical. Our Mist Sprayer Units increase tool life and improve cut edge quality. Automatic operation during cutting ensures consistent results.



EziPanel Pro Software

Reduce the time to create large quantities of panels required for the Aluminium Composite (ACM) market. EZI-Panel Pro eliminates the traditional bottle neck on the design computer. By combining our easy to use software solution with a CNC Router, it is possible to process ACM materials faster, more consistently and at a lower cost than ever before.

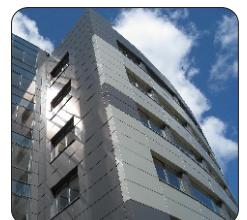



**AUSTRALIAN MADE[®]
AND OWNED**

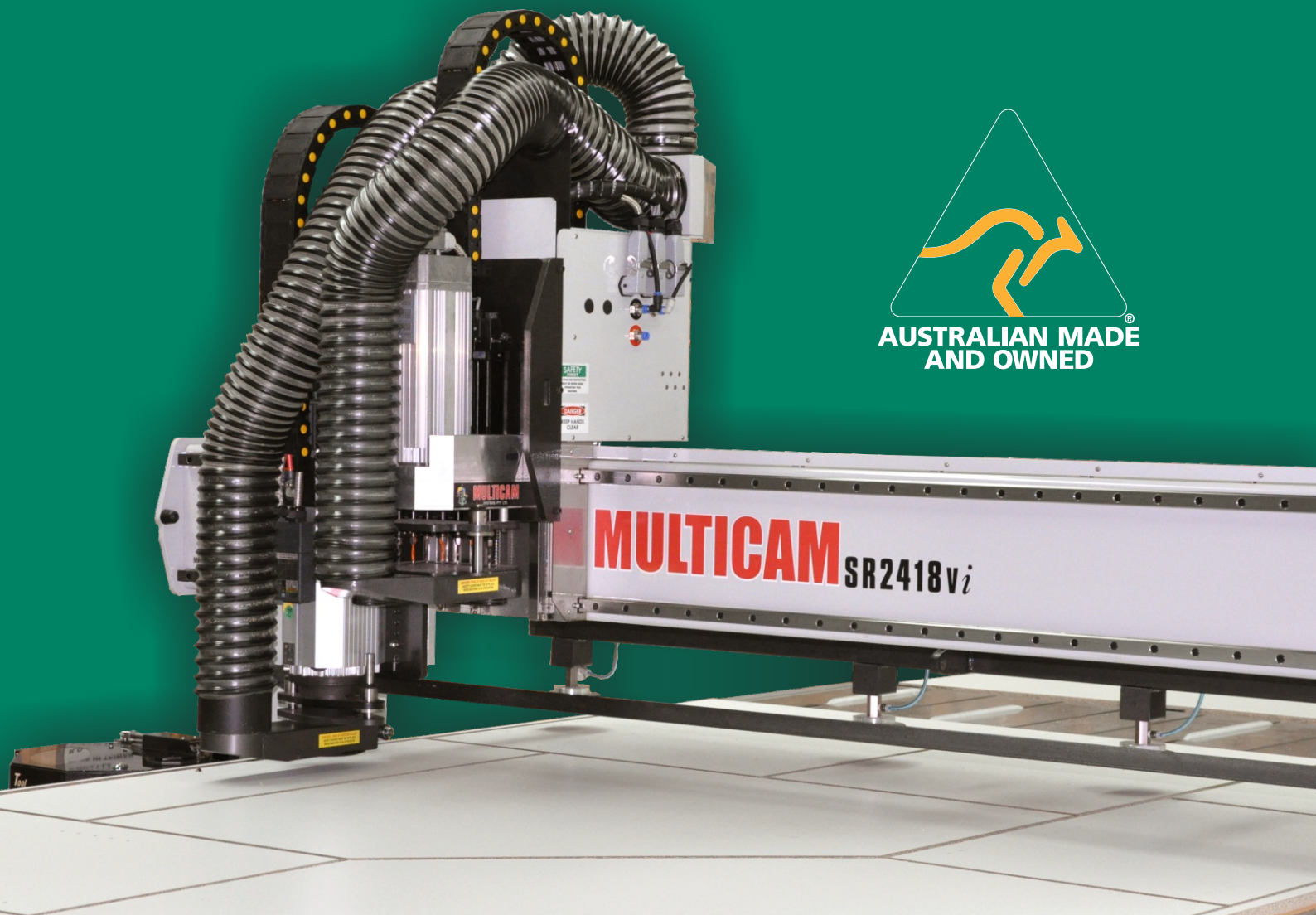

Member of:



Australian
Manufacturing
Technology
Institute
Limited



Australian Woodworking Industry Suppliers Association



MULTICAM
CNC ROUTING MACHINERY

NSW OFFICE:

60 Enterprise Drive,
Beresfield, NSW 2322 Australia
Phone (02) 4964 1900 Fax (02) 4964 1911

VIC OFFICE:

Unit 11, 40 Ricketts Rd
Mt Waverley VIC 3149 Australia
Phone (03) 9558 8022 Fax (03) 9558 8055

QLD OFFICE:

8/42 Trade Street,
Lytton QLD 4178 Australia
Phone (07) 3348 7866 Fax (07) 3348 4366

www.multicam.com.au
sales@multicam.com.au